

SERVICE PARTS LIST FOR MITSUBISHI ELECTRIC PACKAGED AIR-CONDITIONERS

Series : PUHY-(E)P•Y(S)HM-A(-BS)

For use with the R410A

RIVISED

July 2008

BWE0701B

INDEX

**PUHY-P200YHM-A(-BS)
PUHY-P250YHM-A(-BS)
PUHY-P300YHM-A(-BS)
PUHY-P350YHM-A(-BS)
PUHY-P400YHM-A(-BS)
PUHY-P450YHM-A(-BS)
PUHY-EP200YHM-A(-BS)
PUHY-EP300YHM-A(-BS)**

Refer to the next page for the package names.



The Package name list

PUHY-P500YSHM-A(-BS) [PUHY-P250YHM-A(-BS) + PUHY-P250YHM-A(-BS)]

PUHY-P550YSHM-A(-BS) [PUHY-P250YHM-A(-BS) + PUHY-P300YHM-A(-BS)]

PUHY-P600YSHM-A(-BS) [PUHY-P250YHM-A(-BS) + PUHY-P350YHM-A(-BS)]

PUHY-P650YSHM-A(-BS) [PUHY-P300YHM-A(-BS) + PUHY-P350YHM-A(-BS)]

PUHY-P700YSHM-A(-BS) [PUHY-P350YHM-A(-BS) + PUHY-P350YHM-A(-BS)]

PUHY-P750YSHM-A(-BS) [PUHY-P350YHM-A(-BS) + PUHY-P400YHM-A(-BS)]

PUHY-P800YSHM-A(-BS) [PUHY-P350YHM-A(-BS) + PUHY-P450YHM-A(-BS)]

PUHY-P850YSHM-A(-BS) [PUHY-P400YHM-A(-BS) + PUHY-P450YHM-A(-BS)]

PUHY-P900YSHM-A(-BS) [PUHY-P450YHM-A(-BS) + PUHY-P450YHM-A(-BS)]

PUHY-P950YSHM-A(-BS) [PUHY-P250YHM-A(-BS) + PUHY-P300YHM-A(-BS) + PUHY-P400YHM-A(-BS)]

PUHY-P1000YSHM-A(-BS) [PUHY-P300YHM-A(-BS) + PUHY-P300YHM-A(-BS) + PUHY-P400YHM-A(-BS)]

PUHY-P1050YSHM-A(-BS) [PUHY-P300YHM-A(-BS) + PUHY-P350YHM-A(-BS) + PUHY-P400YHM-A(-BS)]

PUHY-P1100YSHM-A(-BS) [PUHY-P350YHM-A(-BS) + PUHY-P350YHM-A(-BS) + PUHY-P400YHM-A(-BS)]

PUHY-P1150YSHM-A(-BS) [PUHY-P350YHM-A(-BS) + PUHY-P350YHM-A(-BS) + PUHY-P450YHM-A(-BS)]

PUHY-P1200YSHM-A(-BS) [PUHY-P350YHM-A(-BS) + PUHY-P400YHM-A(-BS) + PUHY-P450YHM-A(-BS)]

PUHY-P1250YSHM-A(-BS) [PUHY-P350YHM-A(-BS) + PUHY-P450YHM-A(-BS) + PUHY-P450YHM-A(-BS)]

PUHY-EP400YSHM-A(-BS) [PUHY-EP200YHM-A(-BS) + PUHY-EP200YHM-A(-BS)]

PUHY-EP450YSHM-A(-BS) [PUHY-EP200YHM-A(-BS) + PUHY-P250YHM-A(-BS)]

PUHY-EP500YSHM-A(-BS) [PUHY-EP200YHM-A(-BS) + PUHY-EP300YHM-A(-BS)]

PUHY-EP550YSHM-A(-BS) [PUHY-P250YHM-A(-BS) + PUHY-EP300YHM-A(-BS)]

PUHY-EP600YSHM-A(-BS) [PUHY-EP300YHM-A(-BS) + PUHY-EP300YHM-A(-BS)]

PUHY-EP650YSHM-A(-BS) [PUHY-EP300YHM-A(-BS) + PUHY-P350YHM-A(-BS)]

PUHY-EP700YSHM-A(-BS) [PUHY-EP200YHM-A(-BS) + PUHY-EP200YHM-A(-BS) + PUHY-EP300YHM-A(-BS)]

PUHY-EP750YSHM-A(-BS) [PUHY-EP200YHM-A(-BS) + PUHY-P250YHM-A(-BS) + PUHY-EP300YHM-A(-BS)]

PUHY-EP800YSHM-A(-BS) [PUHY-EP200YHM-A(-BS) + PUHY-EP300YHM-A(-BS) + PUHY-EP300YHM-A(-BS)]

PUHY-EP850YSHM-A(-BS) [PUHY-P250YHM-A(-BS) + PUHY-EP300YHM-A(-BS) + PUHY-EP300YHM-A(-BS)]

PUHY-EP900YSHM-A(-BS) [PUHY-EP300YHM-A(-BS) + PUHY-EP300YHM-A(-BS) + PUHY-EP300YHM-A(-BS)]

PUHY-P200,P250,P300YHM-A(-BS)
PUHY-EP200YHM-A(-BS)

EXTERNAL PARTS & BLOWER PARTS (1)

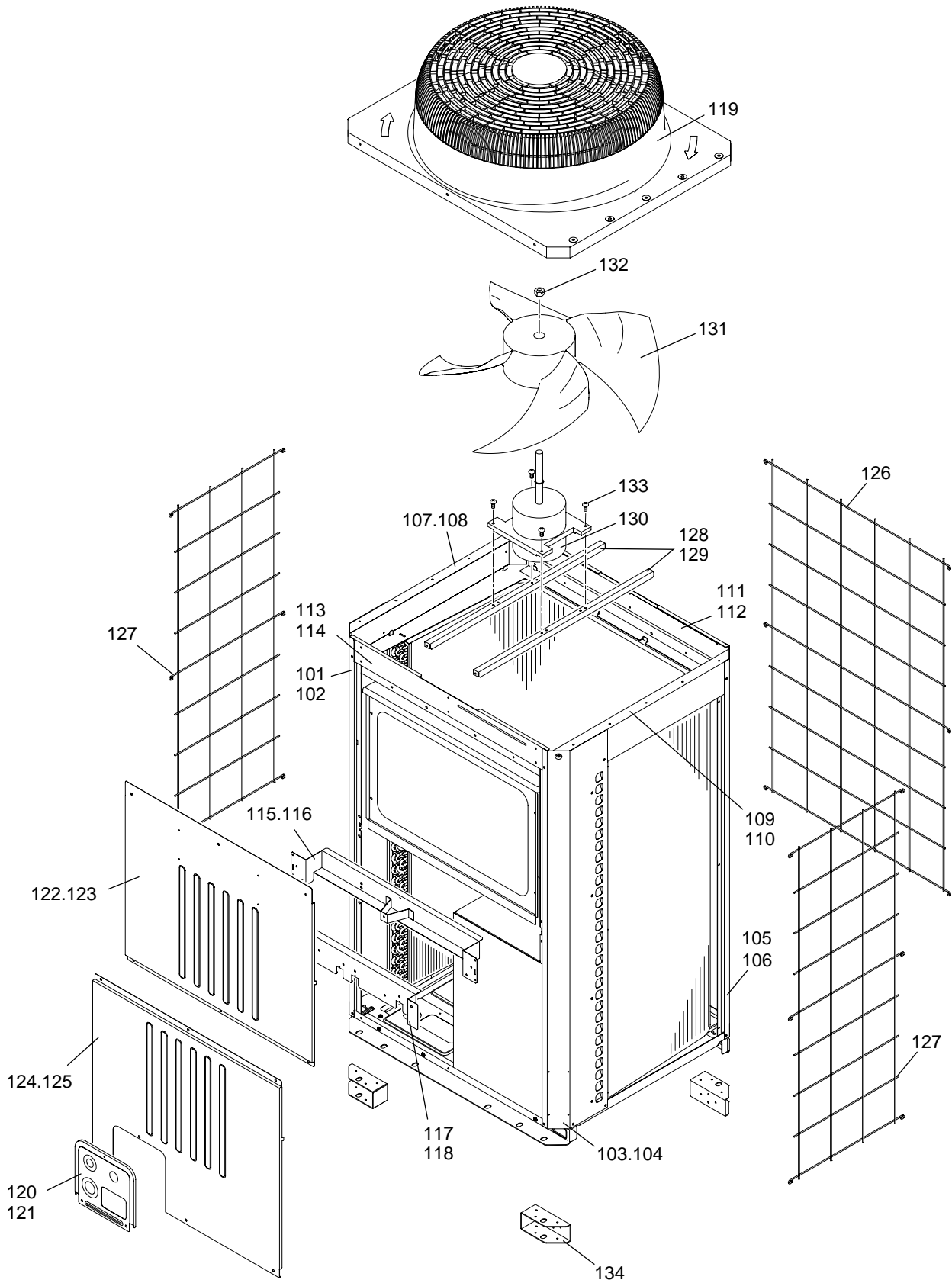

PUHY-P200,P250,P300YHM-A(-BS)
 PUHY-EP200YHM-A(-BS)

EXTERNAL PARTS & BLOWER PARTS (1)

No.	Part No.	G : RoHS Apply Only W : RoHS Apply by Running Change		Spec.	PUHY-P200YHM-A	PUHY-P200YHM-A-BS	PUHY-P250YHM-A	PUHY-P250YHM-A-BS	PUHY-P300YHM-A	PUHY-P300YHM-A-BS	Dwg. No.	Price	Revision History
			Part Name										
101	R63 001 626	G	Pillar LF		1		1		1		KB02A011G05		
102	R63 002 626	G	Pillar LF	BS		1	1		1		KB02A011G06		
103	R63 003 626	G	Pillar RF		1		1		1		KB02A012G05		
104	R63 004 626	G	Pillar RF	BS		1	1		1		KB02A012G06		
105	R63 005 626	G	Pillar B		2		2		2		KB02A013G05		
106	R63 006 626	G	Pillar B	BS		2	2		2		KB02A013G06		
107	R63 005 111	G	Frame assy L		1		1		1		KB00C163G05		
108	R63 006 111	G	Frame assy L	BS		1	1		1		KB00C163G06		
109	R63 007 111	G	Frame assy R		1		1		1		KB00C164G05		
110	R63 008 111	G	Frame assy R	BS		1	1		1		KB00C164G06		
111	R63 009 111	G	Frame assy B		1		1		1		KB00C162G05		
112	R63 010 111	G	Frame assy B	BS		1	1		1		KB00C162G06		
113	R63 011 111	G	Frame F		1		1		1		KB02B021H03		
114	R63 012 111	G	Frame FB	BS		1	1		1		KB02B021G06		
115	R63 013 111	G	Frame assy MU		1		1		1		KB00C887G01		
116	R63 015 111	G	Frame assy MU	BS		1	1		1		KB00C887G03		
117	R63 016 111	G	Frame assy MB		1		1		1		KB00C888G01		
118	R63 018 111	G	Frame assy MB	BS		1	1		1		KB00C888G03		
119	R63 4H6 118	G	Fan guard		1	1	1	1	1	1	KB25A008G02		
120	R63 004 667	G	Pipe cover		1		1		1		KB02C040G03		
121	R63 4H7 667	G	Pipe cover	BS		1	1		1		KB02C040G02		
122	R61 050 651	G	Panel FU		1		1		1		KB02B379H01		
123	R63 4H8 651	G	Panel FU	BS		1	1		1		KB02B379G02		
124	R61 003 652	G	Panel FB	YHM-A	1		1		1		KB02B392H02		
125	R61 004 652	G	Panel FB	YHM-A BS		1	1		1		KB02B392G03		
126	R63 004 611	G	Fin guard B		1	1	1	1	1	1	KB07C042G03		
127	R63 005 611	G	Fin guard LR		2	2	2	2	2	2	KB07C043G02		
128	R63 4H6 140	G	Fan stand		2		2		2		KB02D050H01		
129	R63 4H7 140	G	Fan stand	BS		2	2		2		KB02D050G01		
130	R63 033 220	G	Motor	YC920IA	1	1	1	1	1	1	P780109X01		B
131	R63 4H6 300	G	Fan		1	1	1	1	1	1	KB25A009H02		
132	R63 4H6 122	G	Cap nut	M12 CH	1	1	1	1	1	1	P552000X01		
133	R63 E90 087	G	PT Screw	6x14	4	4	4	4	4	4	P521020X01		
134	R61 016 130	G	Attachment leg		4	4	4	4	4	4	KB02G629G01		

No.	Part No.	G : RoHS Apply Only W : RoHS Apply by Running Change		Spec.	PUHY-EP200YHM-A	PUHY-EP200YHM-A-BS				Dwg. No.	Price	Revision History
			Part Name									
101	R63 001 626	G	Pillar LF		1					KB02A011G05		
102	R63 002 626	G	Pillar LF	BS	1					KB02A011G06		
103	R63 003 626	G	Pillar RF		1					KB02A012G05		
104	R63 004 626	G	Pillar RF	BS	1					KB02A012G06		
105	R63 005 626	G	Pillar B		2					KB02A013G05		
106	R63 006 626	G	Pillar B	BS	2					KB02A013G06		
107	R63 005 111	G	Frame assy L		1					KB00C163G05		
108	R63 006 111	G	Frame assy L	BS	1					KB00C163G06		
109	R63 007 111	G	Frame assy R		1					KB00C164G05		
110	R63 008 111	G	Frame assy R	BS	1					KB00C164G06		
111	R63 009 111	G	Frame assy B		1					KB00C162G05		
112	R63 010 111	G	Frame assy B	BS	1					KB00C162G06		
113	R63 011 111	G	Frame F		1					KB02B021H03		
114	R63 012 111	G	Frame FB	BS	1					KB02B021G06		
115	R63 013 111	G	Frame assy MU		1					KB00C887G01		
116	R63 015 111	G	Frame assy MU	BS	1					KB00C887G03		
117	R63 016 111	G	Frame assy MB		1					KB00C888G01		
118	R63 018 111	G	Frame assy MB	BS	1					KB00C888G03		
119	R63 4H6 118	G	Fan guard		1	1				KB25A008G02		
120	R63 004 667	G	Pipe cover		1					KB02C040G03		
121	R63 4H7 667	G	Pipe cover	BS	1					KB02C040G02		
122	R61 050 651	G	Panel FU		1					KB02B379H01		
123	R63 4H8 651	G	Panel FU	BS	1					KB02B379G02		
124	R61 003 652	G	Panel FB	YHM-A	1					KB02B392H02		
125	R61 004 652	G	Panel FB	YHM-A BS	1					KB02B392G03		
126	R63 004 611	G	Fin guard B		1	1				KB07C042G03		
127	R63 005 611	G	Fin guard LR		2	2				KB07C043G02		
128	R63 4H6 140	G	Fan stand		2					KB02D050H01		
129	R63 4H7 140	G	Fan stand	BS	2					KB02D050G01		
130	R63 033 220	G	Motor	YC920IA	1	1				P780109X01		B
131	R63 4H6 300	G	Fan		1	1				KB25A009H02		
132	R63 4H6 122	G	Cap nut	M12 CH	1	1				P552000X01		
133	R63 E90 087	G	PT Screw	6x14	4	4				P521020X01		
134	R61 016 130	G	Attachment leg		4	4				KB02G629G01		

PUHY-P350,P400,P450YHM-A(-BS)
PUHY-EP300YHM-A(-BS)

EXTERNAL PARTS & BLOWER PARTS (2)

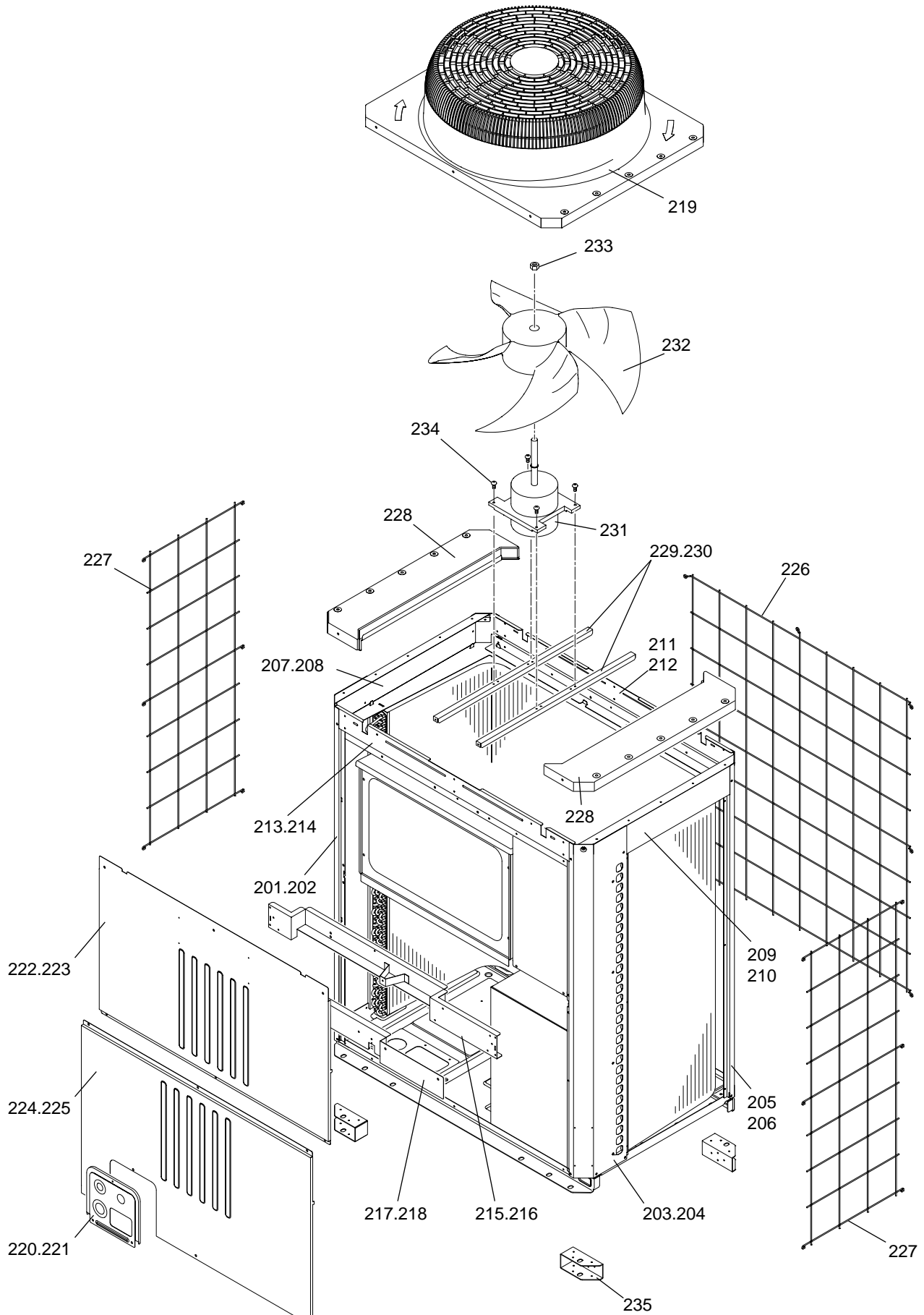

PUHY-P350,P400,P450YHM-A(-BS)
 PUHY-EP300YHM-A(-BS)

EXTERNAL PARTS & BLOWER PARTS (2)

No.	Part No.	G : RoHS Apply Only W : RoHS Apply by Running Change		Spec.	PUHY-P350YHM-A	PUHY-P350YHM-A-BS	PUHY-P400YHM-A	PUHY-P400YHM-A-BS	PUHY-P450YHM-A	PUHY-P450YHM-A-BS	Dwg. No.	Price	Revision History
		Part Name											
201	R63 001 626	G	Pillar LF		1	1	1	1	1	1	KB02A011G05		
202	R63 002 626	G	Pillar LF	BS		1	1	1	1	1	KB02A011G06		
203	R63 003 626	G	Pillar RF		1	1	1	1	1	1	KB02A012G05		
204	R63 004 626	G	Pillar RF	BS		1	1	1	1	1	KB02A012G06		
205	R63 005 626	G	Pillar B		2	2	2	2	2	2	KB02A013G05		
206	R63 006 626	G	Pillar B	BS		2	2	2	2	2	KB02A013G06		
207	R63 005 111	G	Frame assy L		1	1	1	1	1	1	KB00C163G05		
208	R63 006 111	G	Frame assy L	BS		1	1	1	1	1	KB00C163G06		
209	R63 007 111	G	Frame assy R		1	1	1	1	1	1	KB00C164G05		
210	R63 008 111	G	Frame assy R	BS		1	1	1	1	1	KB00C164G06		
211	R63 019 111	G	Frame assy B		1	1	1	1	1	1	KB00C464G03		
212	R63 020 111	G	Frame assy B	BS		1	1	1	1	1	KB00C464G04		
213	R63 021 111	G	Frame F	18HP	1	1	1	1	1	1	KB02B093H03		
214	R63 022 111	G	Frame FB	18HP BS	1	1	1	1	1	1	KB02B093G04		
215	R63 7H6 163	G	Frame assy MU	18HP	1	1	1	1	1	1	KB00C428G04		
216	R63 7H8 163	G	Frame assy MU	18HP BS	1	1	1	1	1	1	KB00C428G06		
217	R61 006 162	G	Frame assy MB	18HP	1	1	1	1	1	1	KB00L186G01		
218	R61 008 162	G	Frame assy MB	18HP BS	1	1	1	1	1	1	KB00L186G03		
219	R63 4H6 118	G	Fan guard		1	1	1	1	1	1	KB25A008G02		
220	R63 004 667	G	Pipe cover		1	1	1	1	1	1	KB02C040G03		
221	R63 4H7 667	G	Pipe cover	BS	1	1	1	1	1	1	KB02C040G02		
222	R61 051 651	G	Panel FU	18HP	1	1	1	1	1	1	KB02B402H01		
223	R63 7H8 651	G	Panel FU	18HP BS	1	1	1	1	1	1	KB02B402G02		
224	R61 005 652	G	Panel FB	18HP YHM-A	1	1	1	1	1	1	KB02B403H02		
225	R61 006 652	G	Panel FB	18HP YHM-A BS	1	1	1	1	1	1	KB02B403G03		
226	R61 006 611	G	Fin guard B	18HP	1	1	1	1	1	1	KB07C377G02		
227	R63 005 611	G	Fin guard LR		2	2	2	2	2	2	KB07C043G02		
228	R63 7H6 118	G	Fan guard cover		2	2	2	2	2	2	KB25B086G01		
229	R63 4H6 140	G	Fan stand		2	2	2	2	2	2	KB02D050H01		
230	R63 4H7 140	G	Fan stand	BS	2	2	2	2	2	2	KB02D050G01		
231	R63 033 220	G	Motor	YC920IA	1	1	1	1	1	1	P780109X01		B
232	R63 4H6 300	G	Fan		1	1	1	1	1	1	KB25A009H02		
233	R63 4H6 122	G	Cap nut	M12 CH	1	1	1	1	1	1	P552000X01		
234	R63 E90 087	G	PT Screw	6x14	4	4	4	4	4	4	P521020X01		
235	R61 016 130	G	Attachment leg		4	4	4	4	4	4	KB02G629G01		

PUHY-P350,P400,P450YHM-A(-BS)
 PUHY-EP300YHM-A(-BS)

EXTERNAL PARTS & BLOWER PARTS (2)

No.	Part No.	G : RoHS Apply Only W : RoHS Apply by Running Change		Spec.	PUHY-EP300YHM-A	PUHY-EP300YHM-A-BS					Dwg. No.	Price	Revision History
			Part Name										
201	R63 001 626	G	Pillar LF		1						KB02A011G05		
202	R63 002 626	G	Pillar LF	BS	1						KB02A011G06		
203	R63 003 626	G	Pillar RF		1						KB02A012G05		
204	R63 004 626	G	Pillar RF	BS	1						KB02A012G06		
205	R63 005 626	G	Pillar B		2						KB02A013G05		
206	R63 006 626	G	Pillar B	BS	2						KB02A013G06		
207	R63 005 111	G	Frame assy L		1						KB00C163G05		
208	R63 006 111	G	Frame assy L	BS	1						KB00C163G06		
209	R63 007 111	G	Frame assy R		1						KB00C164G05		
210	R63 008 111	G	Frame assy R	BS	1						KB00C164G06		
211	R63 019 111	G	Frame assy B		1						KB00C464G03		
212	R63 020 111	G	Frame assy B	BS	1						KB00C464G04		
213	R63 021 111	G	Frame F	18HP	1						KB02B093H03		
214	R63 022 111	G	Frame FB	18HP BS	1						KB02B093G04		
215	R63 7H6 163	G	Frame assy MU	18HP	1						KB00C428G04		
216	R63 7H8 163	G	Frame assy MU	18HP BS	1						KB00C428G06		
217	R61 006 162	G	Frame assy MB	18HP	1						KB00L186G01		
218	R61 008 162	G	Frame assy MB	18HP BS	1						KB00L186G03		
219	R63 4H6 118	G	Fan guard		1	1					KB25A008G02		
220	R63 004 667	G	Pipe cover		1						KB02C040G03		
221	R63 4H7 667	G	Pipe cover	BS	1						KB02C040G02		
222	R61 051 651	G	Panel FU	18HP	1						KB02B402H01		
223	R63 7H8 651	G	Panel FU	18HP BS	1						KB02B402G02		
224	R61 005 652	G	Panel FB	18HP YHM-A	1						KB02B403H02		
225	R61 006 652	G	Panel FB	18HP YHM-A BS	1						KB02B403G03		
226	R61 006 611	G	Fin guard B	18HP	1	1					KB07C377G02		
227	R63 005 611	G	Fin guard LR		2	2					KB07C043G02		
228	R63 7H6 118	G	Fan guard cover		2	2					KB25B086G01		
229	R63 4H6 140	G	Fan stand		2						KB02D050H01		
230	R63 4H7 140	G	Fan stand	BS	2						KB02D050G01		
231	R63 033 220	G	Motor	YC920IA	1	1					P780109X01		B
232	R63 4H6 300	G	Fan		1	1					KB25A009H02		
233	R63 4H6 122	G	Cap nut	M12 CH	1	1					P552000X01		
234	R63 E90 087	G	PT Screw	6×14	4	4					P521020X01		
235	R61 016 130	G	Attachment leg		4	4					KB02G629G01		

PUHY-P200,P250,P300YHM-A(-BS)
PUHY-EP200YHM-A(-BS)

FUNCTIONAL PARTS (1)

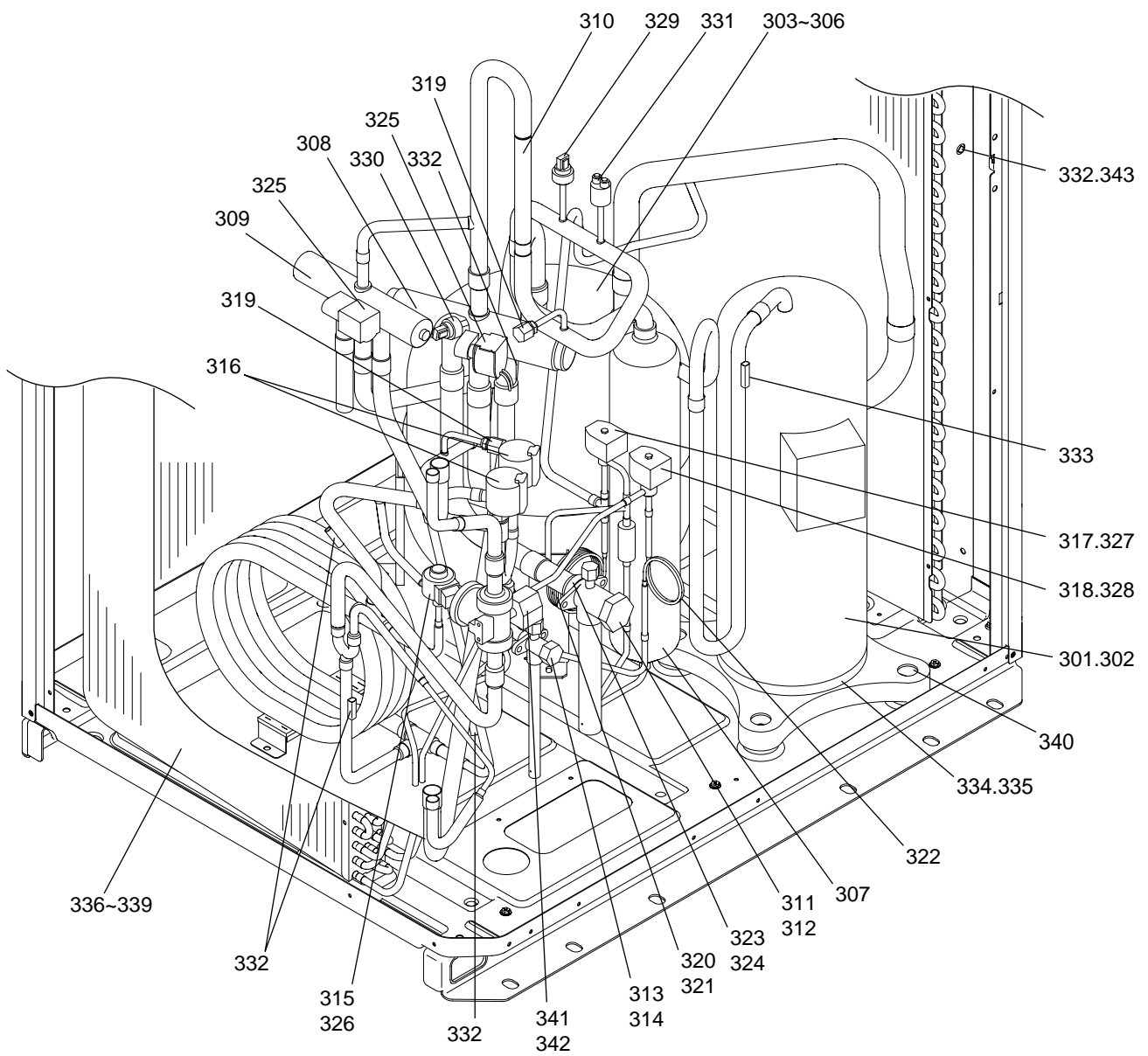

PUHY-P200,P250,P300YHM-A(-BS)
 PUHY-EP200YHM-A(-BS)

FUNCTIONAL PARTS (1)

No.	Part No.	G : RoHS Apply Only W : RoHS Apply by Running Change		Spec.	PUHY-P200YHM-A	PUHY-P200YHM-A-BS	PUHY-P250YHM-A	PUHY-P250YHM-A-BS	PUHY-P300YHM-A	PUHY-P300YHM-A-BS	Dwg. No.	Price	Revision History
			Part Name										
301	R69 023 478	G	Scroll compressor	ENB52FA-YE	1	1	1	1			EP10107B03		
302	R66 A44 478	G	Scroll compressor	HNB71FA-YBE					1	1	EP10092G07		
303	R61 006 484	G	Accumulator assy		1		1				KB54B477G01		
304	R61 007 484	G	Accumulator assy	BS		1		1			KB54B477G02		
305	R61 008 484	G	Accumulator assy						1		KB54B478G01		
306	R61 009 484	G	Accumulator assy	BS						1	KB54B478G02		
307	R61 005 487	G	Oil separator assy		1	1	1	1	1	1	KB00G667G01		
308	R63 Y05 154	G	Four way valve	STF-07	1	1	1	1	1	1	P633119X01		
309	R63 R55 154	G	Four way valve	STF04	1	1	1	1	1	1	P633118X01		
310	R63 R43 418	G	Check valve	BCV-1005	1	1	1	1	1	1	P639165X01		
311	R61 001 540	G	Valve	VSAMH7SSCM-A	1	1					P636342X01		
312	R61 002 540	G	Valve	VSAMH8SSCM-A			1	1	1	1	P636343X01		
313	R61 003 540	G	Valve	VSAMH3SSCM-LA1	1	1	1	1			P636346X01		
314	R61 004 540	G	Valve	VSAMH4SSCM-LA1					1	1	P636345X01		
315	R63 4H6 401	G	Linear expansion valve	CAM35-S	1	1	1	1	1	1	P632444X01		
316	R63 4H7 401	G	Linear expansion valve	EBM-A XA <LEV2a,LEV2b>	2	2	2	2	2	2	P632445X01		
317	R63 P90 232	G	Solenoid valve	VPV-152D	1	1	1	1	1	1	P631277X01		
318	R63 Y07 232	G	Solenoid valve	ATS-A	1	1	1	1	1	1	P631291X01		
319	R63 R34 413	G	Check joint L	R410A	2	2	2	2	2	2	P666001X01		
320	R63 002 425	G	Capillary tube assy		1	1	1	1			KB49F229G01		
321	R63 R34 425	G	Capillary tube assy						1	1	W905625G02		
322	R61 003 425	G	Capillary tube assy		1	1	1	1	1	1	KB49F761G01		
323	R63 4H6 454	G	Strainer	19.05D	1	1					P641133X01		B
324	R63 5H4 454	G	Strainer	25.4D			1	1	1	1	P641134X01		B
325	R63 Y16 243	G	Four way valve coil	STF DV <21S4a,21S4b>	2	2	2	2	2	2	P472024X01		
326	R63 4H6 402	G	Linear expansion valve coil	CAM <LEV1>	1	1	1	1	1	1	P472035X02		
327	R61 006 243	G	Solenoid valve coil	VPV Y <SV1a>	1	1	1	1	1	1	P472046X01		
328	R63 Y18 243	G	Solenoid valve coil	<SV9>	1	1	1	1	1	1	P472012X01		
329	R61 T01 227	G	Pressure sensor	HP <63HS1>	1	1	1	1	1	1	KB00F899G01		
330	R61 T01 228	G	Pressure sensor	LP <63LS>	1	1	1	1	1	1	KB00F899G02		
331	R63 Y11 208	G	Pressure switch	ACB1UB28W <63H1>	1	1	1	1	1	1	P426320X01		
332	R63 670 202	G	Thermistor	MDW103H <TH2,TH3,TH5-7>	5	5	5	5	5	5	P425496X01		
333	R63 911 202	G	Thermistor	<TH4>	1	1	1	1	1	1	P425416X02		
334	R61 003 237	G	Belt heater	240V 35W	1	1	1	1			P497067X01		B
335	R63 Y07 237	G	Belt heater	240V 45W					1	1	P493781X02		
336	R61 105 480	G	Heat exchanger assy	2L	1						KB01G561G01		
337	R61 096 480	G	Heat exchanger assy	2L BS		1					KB01G561G02		
338	R61 097 480	G	Heat exchanger assy	3L			1		1		KB01G562G01		
339	R61 100 480	G	Heat exchanger assy	3L BS				1		1	KB01G562G02		
340	R63 852 860	G	Rubber mount	For compressor	4	4	4	4	4	4	W897574H01		
341	R63 P89 232	G	Solenoid valve	SR6PF-06WR	1	1	1	1	1	1	P631278X01		
342	R61 007 243	G	Solenoid valve coil	SR10D <SV5b>	1	1	1	1	1	1	P472030X02		
343	R61 001 310	G	Sensor holder		1	1	1	1	1	1	KB25B471G02		

No.	Part No.	G : RoHS Apply Only W : RoHS Apply by Running Change		Spec.	PUHY-EP200YHM-A	PUHY-EP200YHM-A-BS				Dwg. No.	Price	Revision History
			Part Name									
301	R69 023 478	G	Scroll compressor	ENB52FA-YE	1	1				EP10107B03		
302	R66 A44 478	G	Scroll compressor	HNB71FA-YBE						EP10092G07		
303	R61 006 484	G	Accumulator assy		1					KB54B477G01		
304	R61 007 484	G	Accumulator assy	BS		1				KB54B477G02		
305	R61 008 484	G	Accumulator assy							KB54B478G01		
306	R61 009 484	G	Accumulator assy	BS						KB54B478G02		
307	R61 005 487	G	Oil separator assy		1	1				KB00G667G01		
308	R63 Y05 154	G	Four way valve	STF-07	1	1				P633119X01		
309	R63 R55 154	G	Four way valve	STF04	1	1				P633118X01		
310	R63 R43 418	G	Check valve	BCV-1005	1	1				P639165X01		
311	R61 001 540	G	Valve	VSAMH7SSCM-A						P636342X01		
312	R61 002 540	G	Valve	VSAMH8SSCM-A	1	1				P636343X01		
313	R61 003 540	G	Valve	VSAMH3SSCM-LA1	1	1				P636346X01		
314	R61 004 540	G	Valve	VSAMH4SSCM-LA1						P636345X01		
315	R63 4H6 401	G	Linear expansion valve	CAM35-S	1	1				P632444X01		
316	R63 4H7 401	G	Linear expansion valve	EBM-A XA <LEV2a,LEV2b>	2	2				P632445X01		
317	R63 P90 232	G	Solenoid valve	VPV-152D	1	1				P631277X01		
318	R63 Y07 232	G	Solenoid valve	ATS-A	1	1				P631291X01		
319	R63 R34 413	G	Check joint L	R410A	2	2				P666001X01		
320	R63 002 425	G	Capillary tube assy		1	1				KB49F229G01		
321	R63 R34 425	G	Capillary tube assy							W905625G02		
322	R61 003 425	G	Capillary tube assy		1	1				KB49F761G01		
323	R63 4H6 454	G	Strainer	19.05D						P641133X01		B
324	R63 5H4 454	G	Strainer	25.4D	1	1				P641134X01		B
325	R63 Y16 243	G	Four way valve coil	STF DV <21S4a,21S4b>	2	2				P472024X01		
326	R63 4H6 402	G	Linear expansion valve coil	CAM <LEV1>	1	1				P472035X02		
327	R61 006 243	G	Solenoid valve coil	VPV Y <SV1a>	1	1				P472046X01		
328	R63 Y18 243	G	Solenoid valve coil	<SV9>	1	1				P472012X01		
329	R61 T01 227	G	Pressure sensor	HP <63HS1>	1	1				KB00F899G01		
330	R61 T01 228	G	Pressure sensor	LP <63LS>	1	1				KB00F899G02		
331	R63 Y11 208	G	Pressure switch	ACB1UB28W <63H1>	1	1				P426320X01		
332	R63 670 202	G	Thermistor	MDW103H <TH2,TH3,TH5-7>	5	5				P425496X01		
333	R63 911 202	G	Thermistor	<TH4>	1	1				P425416X02		
334	R61 003 237	G	Belt heater	240V 35W	1	1				P497067X01		B
335	R63 Y07 237	G	Belt heater	240V 45W						P493781X02		
336	R61 105 480	G	Heat exchanger assy	2L						KB01G561G01		
337	R61 096 480	G	Heat exchanger assy	2L BS						KB01G561G02		
338	R61 097 480	G	Heat exchanger assy	3L	1					KB01G562G01		
339	R61 100 480	G	Heat exchanger assy	3L BS		1				KB01G562G02		
340	R63 852 860	G	Rubber mount	For compressor	4	4				W897574H01		
341	R63 P89 232	G	Solenoid valve	SR6PF-06WR	1	1				P631278X01		
342	R61 007 243	G	Solenoid valve coil	SR10D <SV5b>	1	1				P472030X02		
343	R61 001 310	G	Sensor holder		1	1				KB25B471G02		

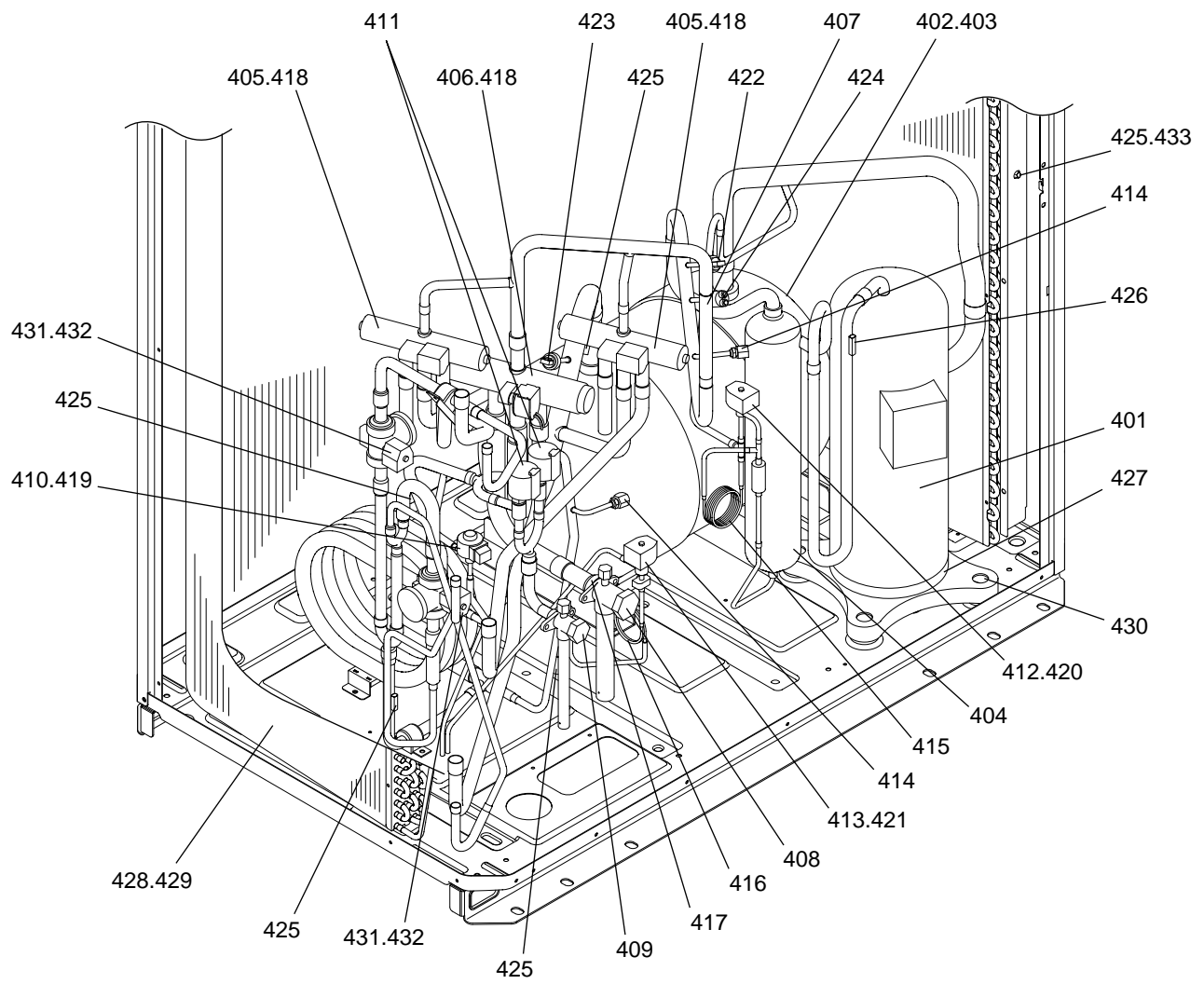

PUHY-P350,P400,P450YHM-A(-BS)
PUHY-EP300YHM-A(-BS)

FUNCTIONAL PARTS (2)

No.	Part No.	G : RoHS Apply Only W : RoHS Apply by Running Change		Spec.	PUHY-P350YHM-A	PUHY-P350YHM-A-BS	PUHY-P400YHM-A	PUHY-P400YHM-A-BS	PUHY-P450YHM-A	PUHY-P450YHM-A-BS	Dwg. No.	Price	Revision History
		Part Name											
401	R69 025 478	G	Scroll compressor	HNB78FA-YE	1	1	1	1	1	1	EP10109B02		
402	R61 010 484	G	Accumulator assy		1		1		1		KB54B479G01		
403	R61 011 484	G	Accumulator assy	BS		1		1		1	KB54B479G02		
404	R61 005 487	G	Oil separator assy		1	1	1	1	1	1	KB00G667G01		
405	R63 R55 154	G	Four way valve	STF04	2	2	2	2	2	2	P633118X01		
406	R63 Y05 154	G	Four way valve	STF-07	1	1	1	1	1	1	P633119X01		
407	R63 R43 418	G	Check valve	BCV-1005	1	1	1	1	1	1	P639165X01		
408	R61 002 540	G	Valve	VSAMH8SSCM-A	1	1	1	1	1	1	P636343X01		
409	R61 005 540	G	Valve	VSAMH5SSCM-LA1	1	1	1	1	1	1	P636344X01		
410	R63 4H6 401	G	Linear expansion valve	CAM35-S	1	1	1	1	1	1	P632444X01		
411	R63 4H7 401	G	Linear expansion valve	EBM-A XA <LEV2a,LEV2b>	2	2	2	2	2	2	P632445X01		
412	R63 P90 232	G	Solenoid valve	VPV-152D	1	1	1	1	1	1	P631277X01		
413	R63 Y07 232	G	Solenoid valve	ATS-A	1	1	1	1	1	1	P631291X01		
414	R63 R34 413	G	Check joint L	R410A	2	2	2	2	2	2	P666001X01		
415	R63 R55 425	G	Capillary tube assy		1	1	1	1	1	1	W905191G02		
416	R61 003 425	G	Capillary tube assy		1	1	1	1	1	1	KB49F761G01		
417	R63 5H4 454	G	Strainer	25.4D	1	1	1	1	1	1	P641125X01		
418	R63 Y16 243	G	Four way valve coil	STF DV <21S4a,21S4b,21S4c>	3	3	3	3	3	3	P472024X01		
419	R63 4H6 402	G	Linear expansion valve coil	CAM <LEV1>	1	1	1	1	1	1	P472035X02		
420	R61 006 243	G	Solenoid valve coil	VPV Y <SV1a>	1	1	1	1	1	1	P472046X01		
421	R63 Y18 243	G	Solenoid valve coil	<SV9>	1	1	1	1	1	1	P472012X01		
422	R61 T01 227	G	Pressure sensor	HP <63HS1>	1	1	1	1	1	1	KB00F899G01		
423	R61 T01 228	G	Pressure sensor	LP <63LS>	1	1	1	1	1	1	KB00F899G02		
424	R63 Y11 208	G	Pressure switch	ACB1UB28W <63H1>	1	1	1	1	1	1	P426320X01		
425	R63 670 202	G	Thermistor	MDW103H <TH2,TH3,TH5-7>	5	5	5	5	5	5	P425496X01		
426	R63 911 202	G	Thermistor	<TH4>	1	1	1	1	1	1	P425416X02		
427	R63 Y07 237	G	Belt heater	240V 45W	1	1	1	1	1	1	P493781X02		
428	R61 115 480	G	Heat exchanger assy	3L	1		1		1		KB01G577G01		
429	R61 116 480	G	Heat exchanger assy	3L BS		1		1		1	KB01G577G02		
430	R63 852 860	G	Rubber mount	For compressor	4	4	4	4	4	4	W897574H01		
431	R63 P89 232	G	Solenoid valve	SR6PF-06WR	2	2	2	2	2	2	P631278X01		
432	R61 007 243	G	Solenoid valve coil	SR10D <SV5b,SV5c>	2	2	2	2	2	2	P472030X02		
433	R61 001 310	G	Sensor holder		1	1	1	1	1	1	KB25B471G02		

No.	Part No.	G : RoHS Apply Only W : RoHS Apply by Running Change		Spec.	PUHY-EP300YHM-A	PUHY-EP300YHM-A-BS					Dwg. No.	Price	Revision History
			Part Name										
401	R69 025 478	G	Scroll compressor	HNB78FA-YE	1	1					EP10109B02		
402	R61 010 484	G	Accumulator assy		1						KB54B479G01		
403	R61 011 484	G	Accumulator assy	BS		1					KB54B479G02		
404	R61 005 487	G	Oil separator assy		1	1					KB00G667G01		
405	R63 R55 154	G	Four way valve	STF04	2	2					P633118X01		
406	R63 Y05 154	G	Four way valve	STF-07	1	1					P633119X01		
407	R63 R43 418	G	Check valve	BCV-1005	1	1					P639165X01		
408	R61 002 540	G	Valve	VSAMH8SSCM-A	1	1					P636343X01		
409	R61 005 540	G	Valve	VSAMH5SSCM-LA1	1	1					P636344X01		
410	R63 4H6 401	G	Linear expansion valve	CAM35-S	1	1					P632444X01		
411	R63 4H7 401	G	Linear expansion valve	EBM-A XA <LEV2a,LEV2b>	2	2					P632445X01		
412	R63 P90 232	G	Solenoid valve	VPV-152D	1	1					P631277X01		
413	R63 Y07 232	G	Solenoid valve	ATS-A	1	1					P631291X01		
414	R63 R34 413	G	Check joint L	R410A	2	2					P666001X01		
415	R63 R55 425	G	Capillary tube assy		1	1					W905191G02		
416	R61 003 425	G	Capillary tube assy		1	1					KB49F761G01		
417	R63 5H4 454	G	Strainer	25.4D	1	1					P641125X01		
418	R63 Y16 243	G	Four way valve coil	STF DV <21S4a,21S4b,21S4c>	3	3					P472024X01		
419	R63 4H6 402	G	Linear expansion valve coil	CAM <LEV1>	1	1					P472035X02		
420	R61 006 243	G	Solenoid valve coil	VPV Y <SV1a>	1	1					P472046X01		
421	R63 Y18 243	G	Solenoid valve coil	<SV9>	1	1					P472012X01		
422	R61 T01 227	G	Pressure sensor	HP <63HS1>	1	1					KB00F899G01		
423	R61 T01 228	G	Pressure sensor	LP <63LS>	1	1					KB00F899G02		
424	R63 Y11 208	G	Pressure switch	ACB1UB28W <63H1>	1	1					P426320X01		
425	R63 670 202	G	Thermistor	MDW103H <TH2,TH3,TH5~7>	5	5					P425496X01		
426	R63 911 202	G	Thermistor	<TH4>	1	1					P425416X02		
427	R63 Y07 237	G	Belt heater	240V 45W	1	1					P493781X02		
428	R61 115 480	G	Heat exchanger assy	3L	1						KB01G577G01		
429	R61 116 480	G	Heat exchanger assy	3L BS		1					KB01G577G02		
430	R63 852 860	G	Rubber mount	For compressor	4	4					W897574H01		
431	R63 P89 232	G	Solenoid valve	SR6PF-06WR	2	2					P631278X01		
432	R61 007 243	G	Solenoid valve coil	SR10D <SV5b,SV5c>	2	2					P472030X02		
433	R61 001 310	G	Sensor holder		1	1					KB25B471G02		

PUHY-P200,P250,P300YHM-A(-BS)
PUHY-P350,P400,P450YHM-A(-BS)
PUHY-EP200,EP300YHM-A(-BS)

CONTROL BOX PARTS

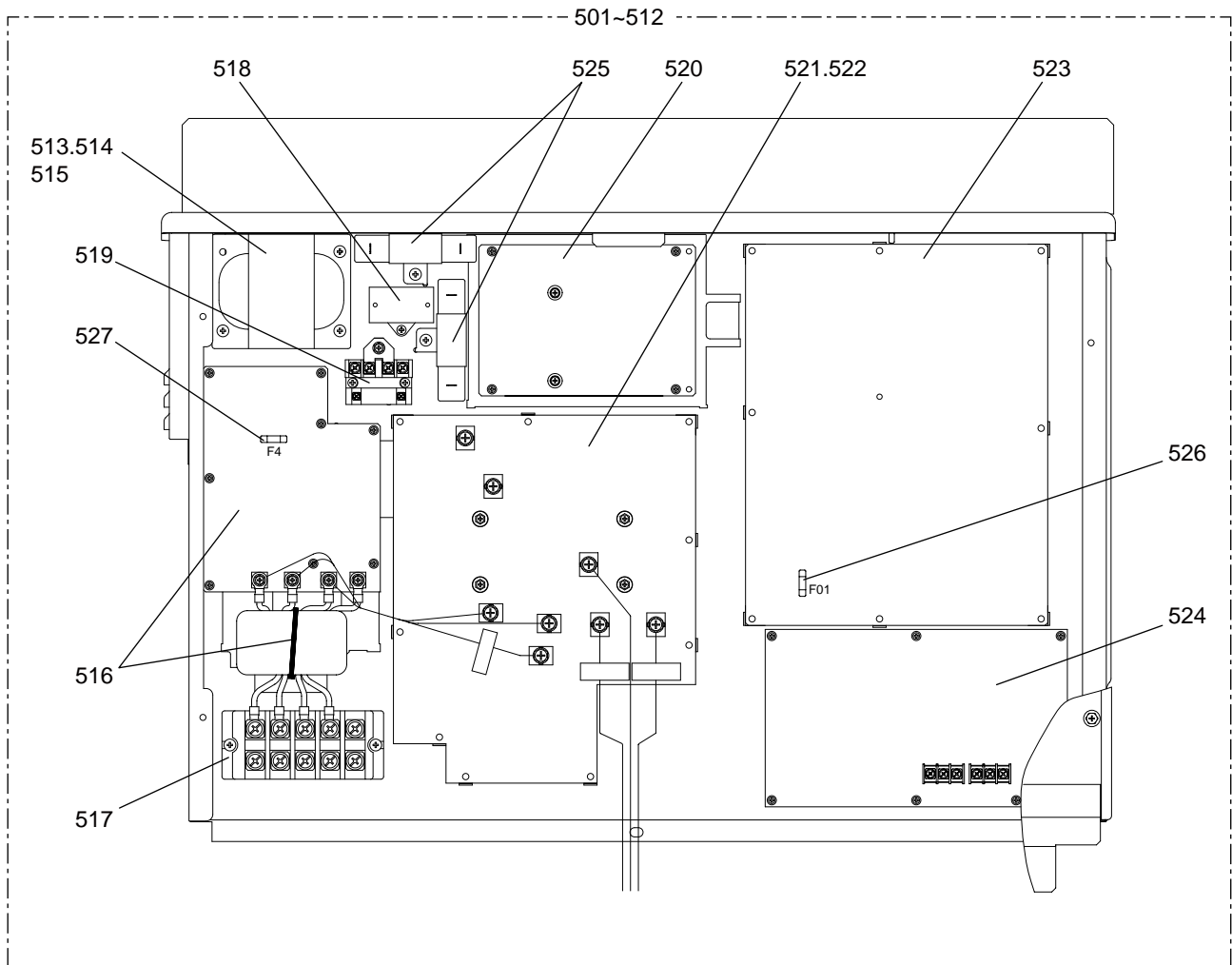

PUHY-P200,P250,P300YHM-A(-BS)
 PUHY-P350,P400,P450YHM-A(-BS)
 PUHY-EP200,EP300YHM-A(-BS)

CONTROL BOX PARTS

No.	Part No.	G : RoHS Apply Only W : RoHS Apply by Running Change	Part Name	Spec.	PUHY-P200YHM-A	PUHY-P200YHM-A-BS	PUHY-P250YHM-A	PUHY-P250YHM-A-BS	PUHY-P300YHM-A	PUHY-P300YHM-A-BS	Dwg. No.	Price	Revision History	
501	R61 047 305	G	Control box	P250YHM	1		1				KE80C152G01			
502	R61 048 305	G	Control box	P250 BS		1		1			KE80C152G02			
503	R61 049 305	G	Control box	P300YHM						1	KE80C152G03			
504	R61 050 305	G	Control box	P300 BS						1	KE80C152G04			
505	R61 051 305	G	Control box	P350YHM							KE80C152G05			
506	R61 052 305	G	Control box	P350 BS							KE80C152G06			
507	R61 053 305	G	Control box	P450YHM							KE80C152G07			
508	R61 054 305	G	Control box	P450 BS							KE80C152G08			
509	R61 055 305	G	Control box	EP200YHM							KE80C152G09			
510	R61 056 305	G	Control box	EP200 BS							KE80C152G10			
511	R61 057 305	G	Control box	EP300YHM							KE80C152G11			
512	R61 058 305	G	Control box	EP300 BS							KE80C152G12			
513	R61 010 259	G	Reactor	<DCL>	1	1	1	1			P715439X01			
514	R61 011 259	G	Reactor	<DCL>						1	1	P715440X01		
515	R61 012 259	G	Reactor	<DCL>								P715441X01		
516	R61 003 293	G	Noise filter	<Noise Filter,L>	1	1	1	1	1	1	KE80C155G01			
517	R61 007 246	G	Terminal block	<TB1>	1	1	1	1	1	1	S436005H12			
518	R61 001 255	G	Capacitor assy	<C100>	1	1	1	1	1	1	KE00D263G01			
519	R61 003 216	G	Relay	<72C>	1	1	1	1	1	1	P421295X01			
520	R61 037 280	G	FAN board		1	1	1	1	1	1	W652171G07			
521	R61 038 280	G	INV board		1	1	1	1			KE80C154G01			
522	R61 039 280	G	INV board							1	1	KE80C154G02		
523	R61 011 281	G	Control board		1	1	1	1	1	1	KE80C153G01			
524	R61 012 281	G	M-NET board		1	1	1	1	1	1	KE80C055G03			
525	R61 001 234	G	Resistor	<R1>,<R5>	2	2	2	2	2	2	P411151X01			
526	R63 992 964	G	Fuse	3.15A AC250V T	1	1	1	1	1	1	S423001H29			
527	R63 993 964	G	Fuse	6.3A AC250V T	1	1	1	1	1	1	S423001H30			

PUHY-P200,P250,P300YHM-A(-BS)
 PUHY-P350,P400,P450YHM-A(-BS)
 PUHY-EP200,EP300YHM-A(-BS)

CONTROL BOX PARTS

No.	Part No.	G : RoHS Apply Only W : RoHS Apply by Running Change	Part Name	Spec.	PUHY-P350YHM-A	PUHY-P350YHM-A-BS	PUHY-P400YHM-A	PUHY-P400YHM-A-BS	PUHY-P450YHM-A	PUHY-P450YHM-A-BS	Dwg. No.	Price	Revision History
501	R61 047 305	G	Control box	P250YHM							KE80C152G01		
502	R61 048 305	G	Control box	P250 BS							KE80C152G02		
503	R61 049 305	G	Control box	P300YHM							KE80C152G03		
504	R61 050 305	G	Control box	P300 BS							KE80C152G04		
505	R61 051 305	G	Control box	P350YHM	1						KE80C152G05		
506	R61 052 305	G	Control box	P350 BS		1					KE80C152G06		
507	R61 053 305	G	Control box	P450YHM			1		1		KE80C152G07		
508	R61 054 305	G	Control box	P450 BS				1		1	KE80C152G08		
509	R61 055 305	G	Control box	EP200YHM							KE80C152G09		
510	R61 056 305	G	Control box	EP200 BS							KE80C152G10		
511	R61 057 305	G	Control box	EP300YHM							KE80C152G11		
512	R61 058 305	G	Control box	EP300 BS							KE80C152G12		
513	R61 010 259	G	Reactor	<DCL>							P715439X01		
514	R61 011 259	G	Reactor	<DCL>	1	1					P715440X01		
515	R61 012 259	G	Reactor	<DCL>			1	1	1	1	P715441X01		
516	R61 003 293	G	Noise filter	<Noise Filter,L>	1	1	1	1	1	1	KE80C155G01		
517	R61 007 246	G	Terminal block	<TB1>	1	1	1	1	1	1	S436005H12		
518	R61 001 255	G	Capacitor assy	<C100>	1	1	1	1	1	1	KE00D263G01		
519	R61 003 216	G	Relay	<72C>	1	1	1	1	1	1	P421295X01		
520	R61 037 280	G	FAN board		1	1	1	1	1	1	W652171G07		
521	R61 038 280	G	INV board								KE80C154G01		
522	R61 039 280	G	INV board		1	1	1	1	1	1	KE80C154G02		
523	R61 011 281	G	Control board		1	1	1	1	1	1	KE80C153G01		
524	R61 012 281	G	M-NET board		1	1	1	1	1	1	KE80C055G03		
525	R61 001 234	G	Resistor	<R1>,<R5>	2	2	2	2	2	2	P411151X01		
526	R63 992 964	G	Fuse	3.15A AC250V T	1	1	1	1	1	1	S423001H29		
527	R63 993 964	G	Fuse	6.3A AC250V T	1	1	1	1	1	1	S423001H30		

PUHY-P200,P250,P300YHM-A(-BS)
 PUHY-P350,P400,P450YHM-A(-BS)
 PUHY-EP200,EP300YHM-A(-BS)

CONTROL BOX PARTS

No.	Part No.	G : RoHS Apply Only W : RoHS Apply by Running Change		Spec.	PUHY-EP200YHM-A	PUHY-EP200YHM-A-BS	PUHY-EP300YHM-A	PUHY-EP300YHM-A-BS	Dwg. No.	Price	Revision History
		Part Name									
501	R61 047 305	G	Control box	P250YHM					KE80C152G01		
502	R61 048 305	G	Control box	P250 BS					KE80C152G02		
503	R61 049 305	G	Control box	P300YHM					KE80C152G03		
504	R61 050 305	G	Control box	P300 BS					KE80C152G04		
505	R61 051 305	G	Control box	P350YHM					KE80C152G05		
506	R61 052 305	G	Control box	P350 BS					KE80C152G06		
507	R61 053 305	G	Control box	P450YHM					KE80C152G07		
508	R61 054 305	G	Control box	P450 BS					KE80C152G08		
509	R61 055 305	G	Control box	EP200YHM	1				KE80C152G09		
510	R61 056 305	G	Control box	EP200 BS		1			KE80C152G10		
511	R61 057 305	G	Control box	EP300YHM			1		KE80C152G11		
512	R61 058 305	G	Control box	EP300 BS				1	KE80C152G12		
513	R61 010 259	G	Reactor	<DCL>	1	1			P715439X01		
514	R61 011 259	G	Reactor	<DCL>			1	1	P715440X01		
515	R61 012 259	G	Reactor	<DCL>					P715441X01		
516	R61 003 293	G	Noise filter	<Noise Filter,L>	1	1	1	1	KE80C155G01		
517	R61 007 246	G	Terminal block	<TB1>	1	1	1	1	S436005H12		
518	R61 001 255	G	Capacitor assy	<C100>	1	1	1	1	KE00D263G01		
519	R61 003 216	G	Relay	<72C>	1	1	1	1	P421295X01		
520	R61 037 280	G	FAN board		1	1	1	1	W652171G07		
521	R61 038 280	G	INV board		1	1			KE80C154G01		
522	R61 039 280	G	INV board				1	1	KE80C154G02		
523	R61 011 281	G	Control board		1	1	1	1	KE80C153G01		
524	R61 012 281	G	M-NET board		1	1	1	1	KE80C055G03		
525	R61 001 234	G	Resistor	<R1>,<R5>	2	2	2	2	P411151X01		
526	R63 992 964	G	Fuse	3.15A AC250V T	1	1	1	1	S423001H29		
527	R63 993 964	G	Fuse	6.3A AC250V T	1	1	1	1	S423001H30		

